

50'S Retro Style refrigerator with automatic freezer, White, Right hand hinge
EAN13: 8017709219406

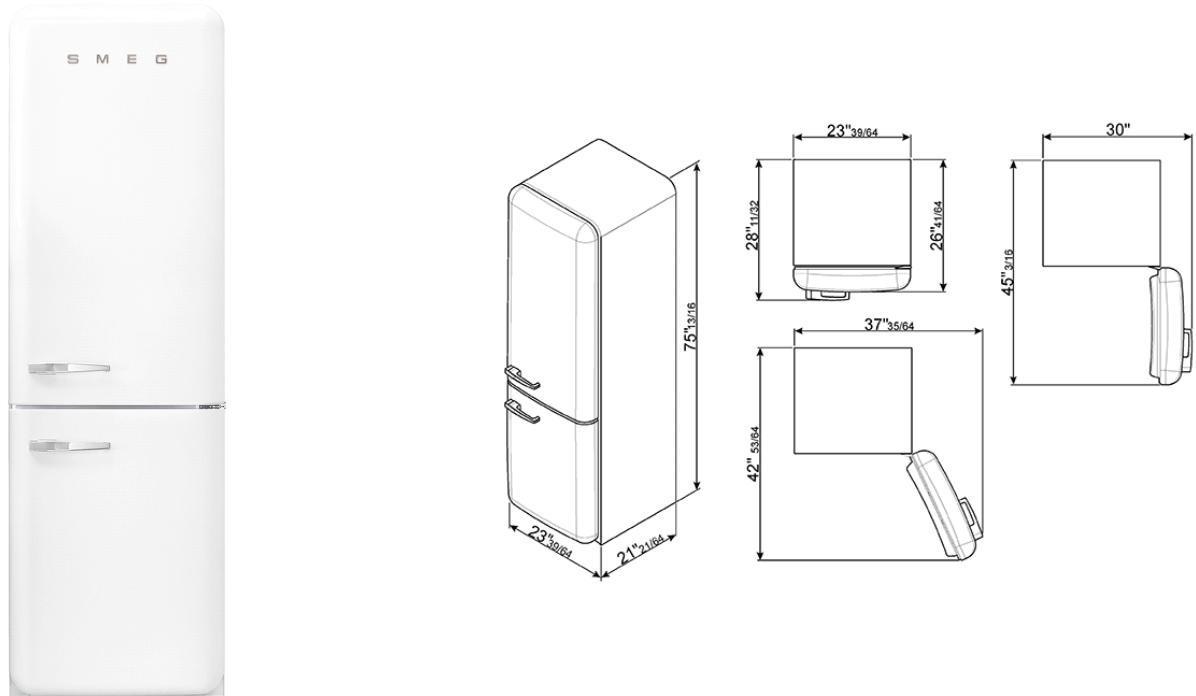

• 2 adjustable thermostats • Freezing capacity: 22 lbs./24 - 10kg/24h • Thaw time: 18h • **REFRIGERATOR:** • Fresh food capacity: 229 liters net capacity • Fresh food capacity: 231 liters gross capacity • Automatic defrost • 3 adjustable glass shelves • 1 fruit and vegetable container • 1 covered storage box • 1 chrome wine rack • **FREEZER ****:** • 3 adjustable shelves • 1 bottle rack • Frost-free • Frozen food capacity: 2.65 cu. ft. net capacity • Frozen food capacity: 3.43 cu. ft. gross capacity • 2 drawers • 1 fast-freezing drawer • Fast-freezing bottom • Ice cube tray • A gap of 175mm must be left on the hinged side of the product to allow the door to open. • Climatic class: SN,N,ST,T • Voltage: 120V • Current: 10Amps • Frequency: 60Hz • Noise level: 41dB(A) RE 1 pW • **DIMENSIONS:** • Dimensions (h x w x d) 1926 x 600 x 677mm • 75"13/16 x 23"39/64 x 26"41/64 inches • Gross weight: 191 lbs • Net weight: 222 lbs • When positioning these appliances adjacent to a kitchen unit, a gap of 6 7/8" must be left on the hinged side of the product to allow the door to open. When positioning next to a wall, it is recommended to leave a larger gap of 12 1/2".

Versions

- FAB32UWHLN - White, left hand hinge