

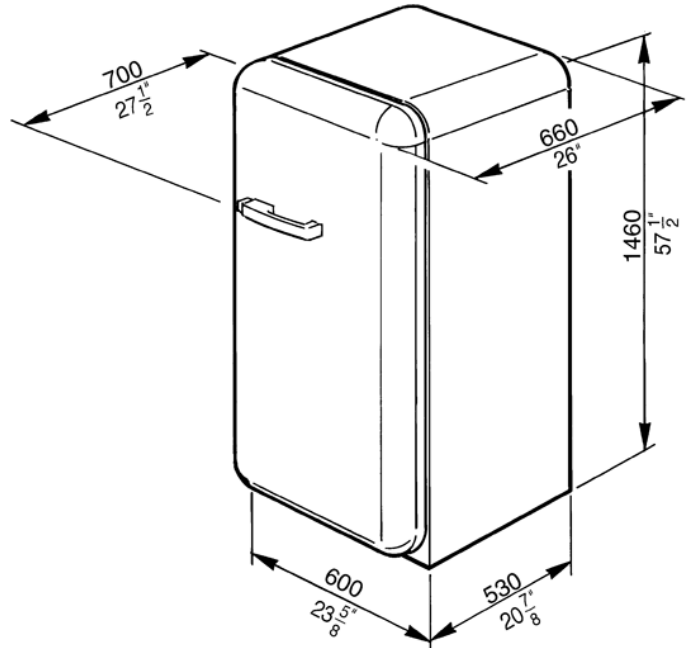

## FAB28UWHR1

50'S Style Refrigerator with ice compartment,  
White, Right hand hinge  
EAN13: 8017709208509



• **Capacity 9.22 cu. ft.** • **REFRIGERATOR:** • Interior light • 3 adjustable glass shelves • 1 bottle rack • 1 fixed glass shelf • 1 fruit and vegetable container • 1 dairy box • **DOOR:** • 2 adjustable covered bins • 2 bottle storage bins • 4 adjustable bins • 2 egg bins • **FREEZER COMPARTMENT** • 1 Ice cube tray • Climatic class: T • Energy consumption: 305 kWh/year • Voltage: 120V • Current: 10Amps • Frequency: 60Hz • Noise level: 42dB(A) RE 1pW • **Dimensions (h x w x d)** • 57½" x 23⅝" x 27½" • Gross weight: 181.4lbs • Net weight: 156.5lbs • When positioning these appliances adjacent to a kitchen unit, a gap of 6 7/8" must be left on the hinged side of the product to allow the door to open. When positioning next to a wall, it is recommended to leave a larger gap of 12 1/2".

### Versions

- FAB28UWHL1 - White, left hand hinge