



CE6GPXU

Free-Standing Dual Fuel Range, 24",
Stainless Steel

EAN13: 8017709121372

AISI 304 stainless steel

Ergonomic control knobs

Storage compartment beneath the oven

5" Polished stainless steel backsplash

Multifunction Electric Oven

9 cooking modes

Electronic clock and program feature

Electronic multi-display

Self cleaning oven

Automatic door lock during self cleaning cycle

Safe cooler quadruple glazed door

Halogen oven lights

Oven capacity: 1.94 Cu. Ft

Bake element: 1300W at 240V - 1100W at 208V

Broil element: 2000W at 240V - 1600W at 208V

Convection element: 2200W at 240V - 1800W at 208V

Gas Rangetop

Heavy duty cast iron grates

Full width grates

Sealed burners

Automatic electronic ignition

Safety valves

LP Gas conversion kit included

4 Gas burners:

Front right: 6,200 BTU burner

Back right: 15,000 = 3,000 (inner) + 12,000 (outer) BTU double inset super burner

Back left: 3,400 BTU rapid burner

Front left: 6,200 BTU burner

Connected load (nominal power): 240V- 3.3kW

Amp supply required @ 240/208V: 15 / 13

Gas inlet location: back right lower



Accessories Included:

- 2 Baking trays
- 2 Wire racks
- 1 Rotisserie kit
- 1 Wok ring
- Tray handle

Functions





Main Oven



ECO:

The Eco setting is a fast preheat function, which combines broil, fan and lower element to achieve optimum energy efficiency. Only to be used prior to selecting the main cooking mode.



Top and bottom heat:

This method is known as "conventional" cooking, and is suitable for dishes that require a more gentle heat, such as baking. The oven needs to be pre-heated to the required temperature, and is best suited for single items, such as large cakes. Best results are obtained by placing food in the centre of the oven.



Rotisserie with broil:

The rotisserie (where installed) works in combination with the broil element to brown foods to perfection.



Convection with top and bottom heat:

The elements combined with the fan aim to provide more uniform heat. This is a similar method to conventional cooking, so pre-heat is required. This is not as effective as european convection cooking but can be used to cook biscuits and pastry.

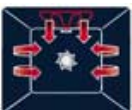

Convection broil:

Please note: cooking in this mode is conducted with the door closed. The fan reduces the fierce heat from the broiler, providing an excellent method for broiling a range of foods; chops, steaks, sausages etc. without having to turn the food during cooking. This gives good results, reduces drying out of foods, and gives even browning and heat distribution, the top two racks being recommended for use. The lower area of the cavity can also be used to keep other items warm at the same time.



Convection with bottom heat:

This combination quickly completes the cooking of foods that are ready on the surface, but require more cooking inside, without further browning. Suitable for any type of food.



European convection:

The combination of the fan and circular element around it, gives uniform heat distribution with no cold spots. This has benefits - no preheat if cook time is more than 20 minutes, no flavour transfer when cooking different foods the same time, less energy is needed, and it cooks at 10% quicker than a normal oven.



European convection with top and bottom heat:

The use of the fan with both elements allows food to be cooked quickly and effectively on a number of oven racks. Ideal for roasts that require thorough cooking. There is no transference of smells or flavours when using this function. This function offers a similar result to rotisserie, it moves the heat around the food, instead of moving the food itself, enabling any size or shape to be cooked, and not only items that will fit onto a rotisserie.



Self-cleaning system:

The self cleaning system cleans at a maximum of 864°F destroying all the dirt deposits inside the oven.



CE6GPXU

concert
24"
stainless steel
cooktops type: gas
oven type: electric multifunction

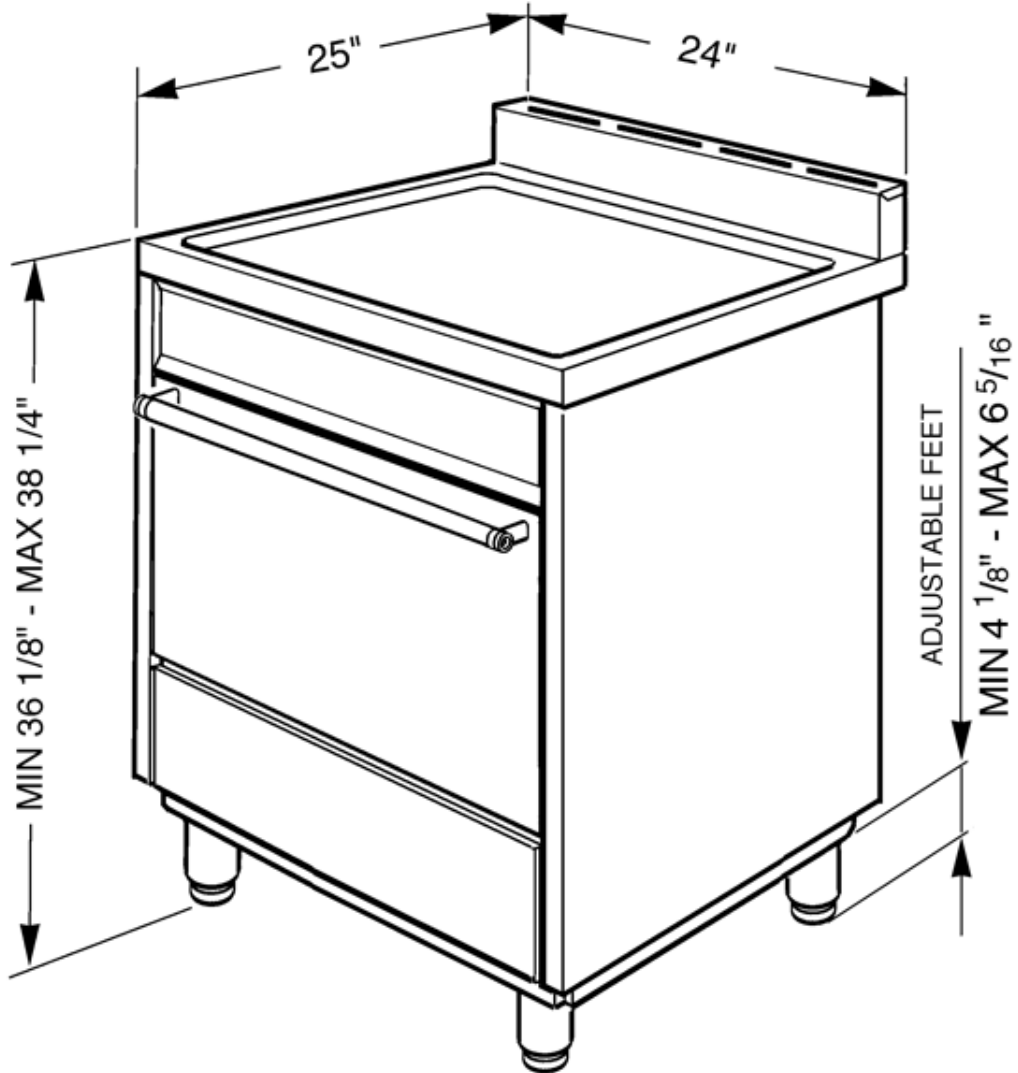

SMEG U.S.A. INC.
A&D BUILDING
150 EAST 58th STREET, 7th FLOOR
NEW YORK, NY, 10155
Tel. +1 212 265 5378
Fax +1 212 265 5945