

FAB5URNE

50's Retro style

50's Retro Style Mini Refrigerator,
Black, Right hand hinge

EAN13: 8017709182250

Capacity 1.5 Cu. Ft.

Absorption cooling = ultra low noise level

LED Internal light

2 adjustable shelves

Door storage: 1 balcony shelf, 1 bottle shelf

Ice cube tray

Voltage: 115 V

Current: 10Amps

Frequency: 60Hz

Dimensions: (H x W x D) 28 9/64" x 15 57/64" x 22 3/64"

Gross Weight: 65lbs.

Net Weight: 51.2 lbs.

Versions

- **FAB5ULNE** - Black, hinges on the left
- **FAB5URO** - Orange, hinges on the right
- **FAB5ULO** - Orange, hinges on the left
- **FAB5URP** - Cream, hinges on the right
- **FAB5ULP** - Cream, hinges on the left
- **FAB5URR** - Red, hinges on the right
- **FAB5ULR** - Red, hinges on the left
- **FAB5URUJ** - Union Jack, hinges on the right
- **FAB5ULUJ** - Union Jack, hinges on the left





FAB5URNE

50's Retro style

fridge
free standing
50's style
black

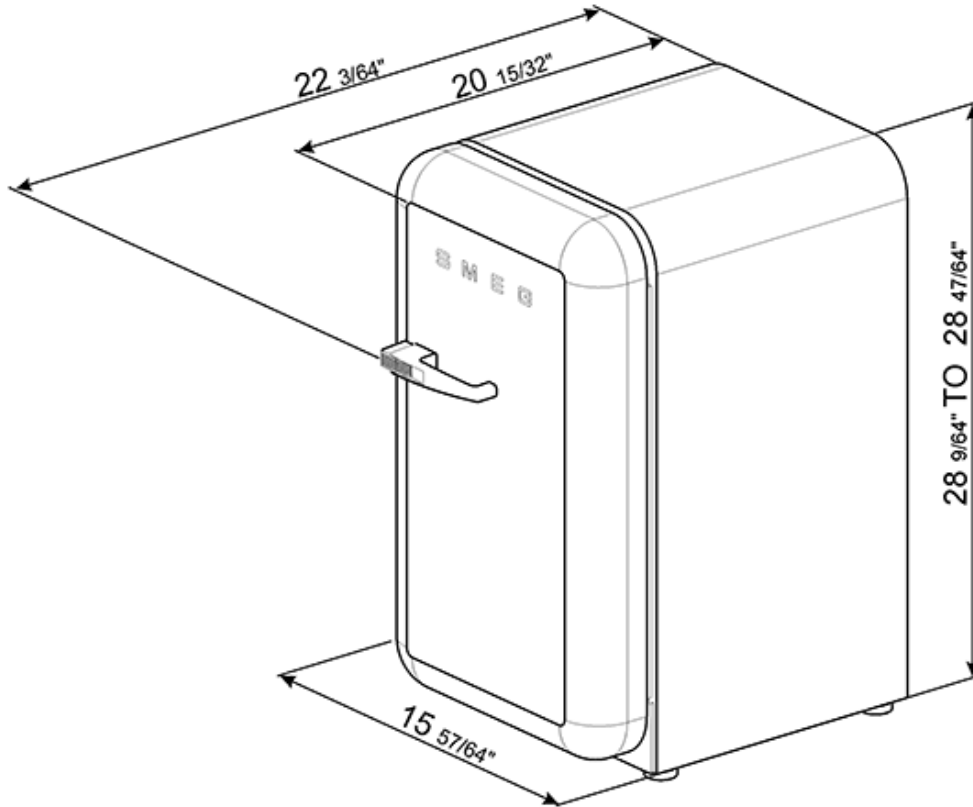

SMEG U.S.A. INC.
A&D BUILDING
150 EAST 58th STREET, 7th FLOOR
NEW YORK, NY, 10155
Tel. +1 212 265 5378
Fax +1 212 265 5945