

## 9.0 cu. ft. TurboSteam® Front Load Dryer

- 9.0 cu. ft. Mega Capacity
- TurboSteam® Technology
- SteamSanitary™ and SteamFresh™ Cycle
- AI Fabric Sensor / Smart Pairing™
- 12 Cycles / 12 Options
- Sensor Dry System
- FlowSense™ Duct Clogging and Lint Filter Indicators
- NeveRust™ Stainless Steel Drum
- LG ThinQ® Technology (Wi-Fi)



### COLOR AVAILABILITY

- DLEX8900B (Electric) – Black Steel
- DLGX8901B (Gas) – Black Steel

### CAPACITY & MATCHING WASHER

Capacity (cu. ft.)	9.0
Matching Washer	WM8900HBA

### APPEARANCE

Electronic Controls with LED Display	Yes
Touch Buttons	Yes
Dial-A-Cycle™	Yes

### DRYER CYCLES

Number of Cycles	12
Sensor Dry Cycles	Normal, Perm Press, Towels, Delicates, Heavy Duty SteamFresh™, SteamSanitary™, Bedding, Small Load
Manual Dry Cycles	Speed Dry, Air Dry, Downloaded

### DRYER OPTIONS

Number of Options	12
Options	TurboSteam®, Damp Dry Signal, More Time, Less Time, Wrinkle Care, Energy Saver, Control Lock, Reduce Static, Signal, Drum Light, Wi-Fi, Remote Start
Temperature Settings	High, Medium High, Medium, Low, Ultra Low
Drying Levels	Very Dry, More Dry, Normal Dry, Less Dry, Damp Dry
Manual Dry Times	60 min., 50 min., 40 min., 30 min., 20 min., More Time / Less Time

### FABRIC CARE

Steam Technology	TurboSteam®
Sensor Dry	Yes
Precise Temperature Control with Variable Heater	Yes

### CONVENIENCE

Drum Light	Yes
Control Lock	Yes
FlowSense™ Duct Clogging Indicator	Yes
End of Cycle Signal	Yes
Remaining Time Display / Status Indicator(s)	Yes
Reversible Door	Yes
Venting Option	Electric: 4 Way Venting Gas: 3 Way Venting
3 Minute Installation Check	Yes
Leveling Legs	4 Adjustable Legs
ADA Compliant	No

### SMART FEATURES

Wi-Fi Enabled	Yes
ThinQ® Technology	Yes
ThinQ Care	Yes
SmartDiagnosis™	Yes
Remote Monitoring & Notifications	Yes

### MATERIALS AND FINISHES

Drum Material	NeveRust™ Stainless Steel
Door / Rim	Glass / Chrome
Door Cover	Dark Blue Tinted Square Cover

### TECHNICAL SPECS

Electrical Requirements	Electric: 240V, 30 Amps Gas: 120V, 15 Amps
Gas Dryer BTU Rating	20,000
Power Outlet Location	Within 48" of Either Side
Plug Type	Gas: 3-Prong (Cord Attached to Unit) Electric: 4-Wire (Cord Required)
ENERGY STAR® Certified	Yes
Combined Energy Factor (CEF)	Electric: 3.94 / Gas: 3.49

### OPTIONAL ACCESSORIES

Pedestal	WDP5B
Pedestal (W x H x D)	29" x 14 1/8" x 30 7/8"
Stacking Kit	KSTK2
Drying Rack	MGR62082001
LP Conversion Kit	383EEL3002D
Side Vent Kit	383EEL9001L

### DIMENSIONS

Product (W x H x D)	29" x 40 3/4" x 32 1/8"
Depth with Door Open	59"
Cutout Dimensions (W x H x D)	31" x 41" x 37 1/8" (34 1/8" D for Side or Bottom Venting)
Carton Dimensions (W x H x D)	31 1/2" x 45 1/8" x 33 7/8"
Approx. Weight (Product / Carton)	Electric: 155 lbs. / 170.6 lbs. Gas: 161 lbs. / 171.5 lbs.

### LIMITED WARRANTY

Parts and Labor	1 Year
Dryer Drum	3 Years (Parts Only)

### DIMENSIONS / CLEARANCES

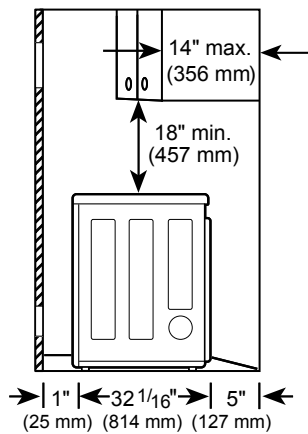

#### SPACING FOR RECESSED AREA OR CLOSET INSTALLATION

The following clearances are recommended for the appliance.

- Additional clearances should be considered for ease of installation and servicing.
- Additional clearances should be considered on all sides of the dryer to reduce noise transfer.

#### CLOSET VENTILATION REQUIREMENTS

Closets with doors must have both an upper and lower vent to prevent heat and moisture buildup in the closet. One upper vent opening with a minimum opening of 48 sq. in. (310 cm<sup>2</sup>) must be installed no lower than 6 feet above the floor. One lower vent opening with a minimum opening of 24 sq. in. (155 cm<sup>2</sup>) must be installed no more than one foot above the floor. Install vent grilles in the door or cut down the door at the top and bottom to form openings. Louvered doors with equivalent ventilation openings are also acceptable.

- There should be at least a little space around the dryer (or any other appliance) to eliminate the transfer of vibration from one appliance to another. If there is enough vibration, it could cause appliances to make noise or come into contact, causing paint damage and further increasing noise.
- No other fuel-burning appliance can be installed in the same closet as a dryer.

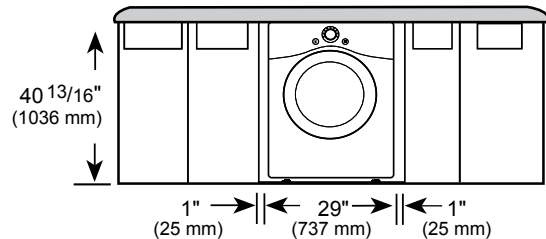
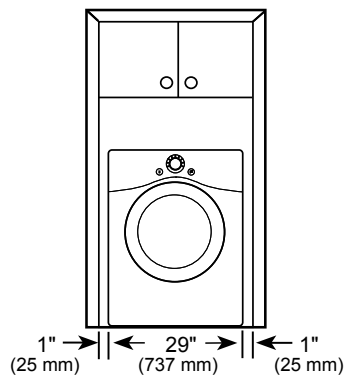
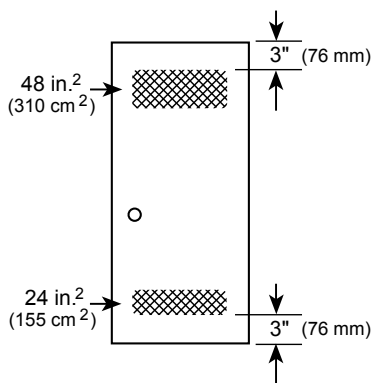

## DIMENSIONS / CLEARANCES

### INSTALLATION SPACING FOR RECESSED AREA OR CLOSET, WITH STACKED WASHER AND DRYER

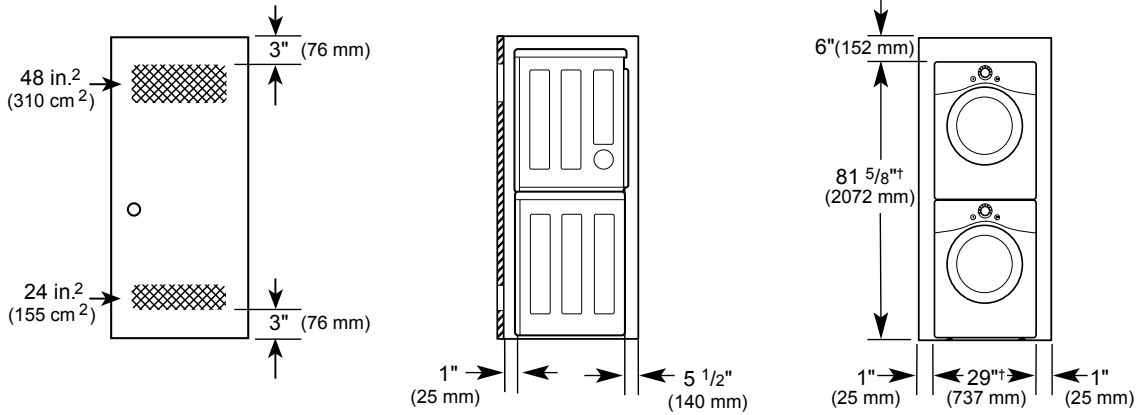

†Differs depending on the washer dimensions.

### CLEARANCES WITH OPTIONAL PEDESTAL BASE

For cabinet installation with a door, minimum ventilation openings in the top of the cabinet are required.

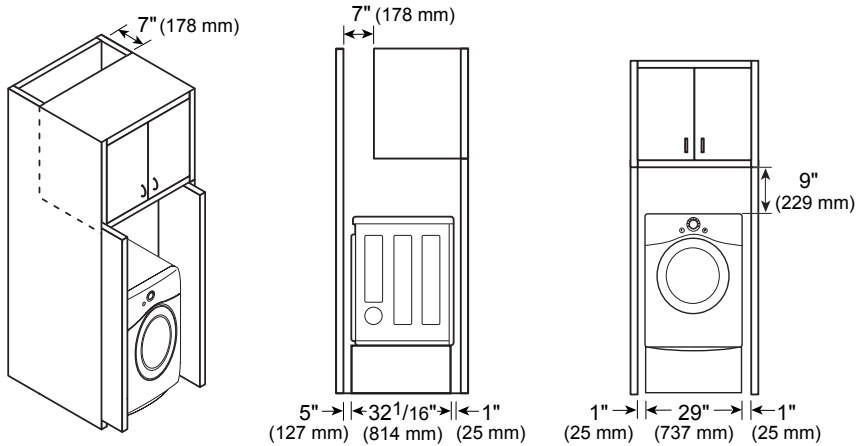

## VENTING THE DRYER

- If connecting to existing ductwork, make sure it is suitable and clean before installing the dryer.
- Venting must conform to local building codes.
- Gas dryers **MUST** exhaust to the outdoors.
- Use only 4-inch (10.2 cm) rigid, semi-rigid or flexible metal ductwork inside the dryer cabinet and for venting outside.
- The exhaust duct must be 4 inches (10.2 cm) in diameter with no obstructions. The exhaust duct should be kept as short as possible. Make sure to clean any old ducts before installing your new dryer.
- Rigid, semi-rigid or flexible metal ducting is recommended for use between the dryer and the wall. All non-rigid metal transition duct must be UL-listed. Use of other materials for transition duct could affect drying time.
- Ductwork is not provided with the dryer. You should obtain the necessary ductwork locally. The vent hood should have hinged dampers to prevent backdraft when the dryer is not in use.
- The total length of flexible metal duct must not exceed 8 ft. (2.4 m).

### NOTE:

- Deduct 6 ft. (1.8 m) for each additional elbow. Do not use more than four 90° elbows.

## ROUTING AND CONNECTING DUCTWORK

### NOTE:

Follow the guidelines below to maximize drying performance and reduce lint buildup and condensation in the ductwork. Ductwork and fittings are **NOT** included and must be purchased separately.

- Use 4-inch (10.2 cm) diameter rigid, semi-rigid or flexible metal ductwork.
- The exhaust duct run should be as short as possible.
- Use as few elbow joints as possible.
- The male end of each section of exhaust duct must point away from the dryer.
- Use duct tape on all duct joints.
- Insulate ductwork that runs through unheated areas in order to reduce condensation and lint buildup on duct surfaces.
- Incorrect or inadequate exhaust systems are not covered by the dryer warranty. Dryer failures or service required because of such exhaust systems will not be covered by the dryer warranty.

## DUCTWORK

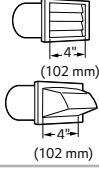
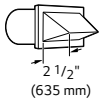
Wall Cap Type	Number of 90° Elbows	Maximum length of 4-inch diameter rigid metal duct
	0	65 ft. (19.8 m)
	1	55 ft. (16.8 m)
	2	47 ft. (14.3 m)
	3	36 ft. (11.0 m)
	4	28 ft. (8.5 m)
	0	55 ft. (16.8 m)
	1	47 ft. (14.3 m)
	2	41 ft. (12.5 m)
	3	30 ft. (9.1 m)
	4	22 ft. (6.7 m)

## CONNECTING GAS DRYERS

### Gas Supply Requirements

- As shipped from the factory, this dryer is configured for use with natural gas (NG). It can be converted for use with propane (LP) gas. Gas pressure must not exceed 8-inch (20.4 cm) water column for NG, or 13-inch (33.1 cm) water column for LP.
- A qualified service or gas company technician must connect the dryer to the gas service.

### Electrical Requirements for Gas Models Only

- This dryer must be plugged into a 120-VAC, 60-Hz. grounded outlet protected by a 15-ampere fuse or circuit breaker.
- This dryer is equipped with a three-prong grounding plug for protection against shock hazard and should be plugged directly into a properly grounded three-prong receptacle. Do not cut or remove the grounding prong from this plug.

## CONNECTING ELECTRIC DRYERS

### Electrical Requirements for Electric Models Only

- This dryer must be connected to a grounded metal, permanent wiring system, or an equipment-grounding conductor must be run with the circuit conductors and connected to the equipment-grounding terminal or lead on the dryer.
- The dryer has its own terminal block that must be connected to a separate 240 VAC, 60-Hertz, single-phase circuit, fused at 30 amperes (the circuit must be fused on both sides of the line). ELECTRICAL SERVICE FOR THE APPLIANCE SHOULD BE OF THE MAXIMUM RATE VOLTAGE LISTED ON THE NAMEPLATE. DO NOT CONNECT THE APPLIANCE TO 110-, 115-, OR 120-VOLT CIRCUIT.
- If the branch circuit to dryer is 15 ft. (4.5 m) or less in length, use UL (Underwriters Laboratories) listed No.-10 AWG wire (copper wire only), or as required by local codes. If over 15 ft. (4.5 m), use UL-listed No.-8 AWG wire (copper wire only), or as required by local codes. Allow sufficient slack in wiring so the dryer can be moved from its normal location when necessary.
- The power cord (pigtail) connection between the wall receptacle and the dryer terminal block IS NOT supplied with the dryer. Type of pigtail and gauge of wire must conform to local codes.

## ELECTRIC & GAS CONNECTION LOCATIONS

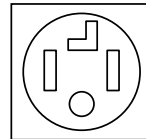
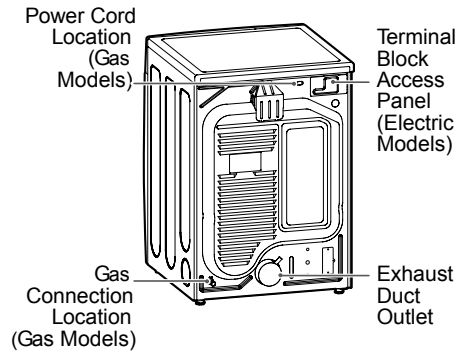

### FOUR-WIRE POWER CORD

- A 4-wire connection is required for all mobile and manufactured home installations, as well as all new construction after January 1, 1996.
- A UL-listed strain relief is required.
- Use a 30-amp, 240-volt, 4-wire, UL-listed power cord with #10 AWG-minimum copper conductor and closed loop or forked terminals with upturned ends.

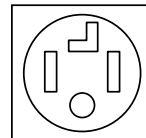

### FOUR-WIRE DIRECT WIRE

- A 4-wire connection is required for all mobile and manufactured home installations, as well as all new construction after January 1, 1996.
- A UL-listed strain relief is required.
- Use UL-listed 4-wire #10 AWG minimum copper conductor cable. Allow at least 5 ft. (1.5 m) of wire to allow for removal and reinstallation of the dryer.